



WALTHAMBURY®



M220/18

M220/18

The Walthambury M220/18 bagging unit is fitted with an 18 degree elevator that makes it ideal for peat, compost, animal feeds, top soil, aggregates, sand and other bulky or free flowing granular materials.

Also the M220/18 has a sealed chevron style belt, spring balance scale, manual sack clamp and is belt driven by suitably sized motor and gear box.

These features make the M220/18 perfect for low throughput bagging operations with its simple, reliable operation.

The M220/18 is suitable for paper, plastic, hessian and jute bags.

- Single belt feed - available with sealed elevator for granular and fibrous materials
- Light-weight chassis allowing for a mobile weighing and bagging platform.
- Up to 220 bags per hour
- Minimum IP44 rating
- Chevron or plain style belt

Optional Extras

- Stainless steel construction for food quality
- Sealed belt for dusty materials.

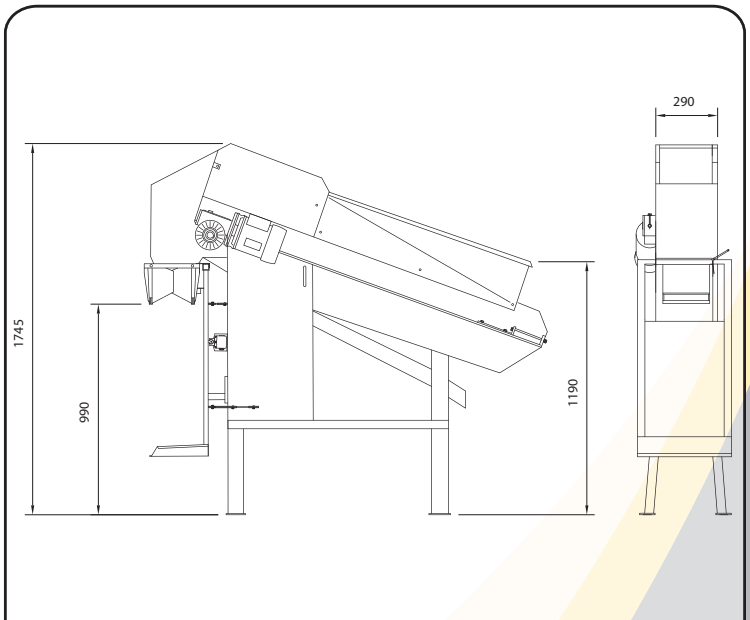

TECHNICAL SPECIFICATIONS

Throughput

Up to 220 bags per hour (depending on produce and bag size)

Weight Range

10kg to 25kg (5 - 25kg optional).

Electrical Requirement

440VAC 3 phase or
240VAC single phase

After Sales Service

Fast on site service by factory trained engineers coupled with extensive stocks of competitively priced spare parts guarantees maximum productivity and protects the customer's investment.



Walthambury

New Walthambury House,
Anglia Way, Braintree,
Essex, CM7 3RG, UK.
Tel: +44 (0)1376 322722
Fax: +44 (0)1376 323277
E-Mail: sales@morrays.com
www.walthambury.com