

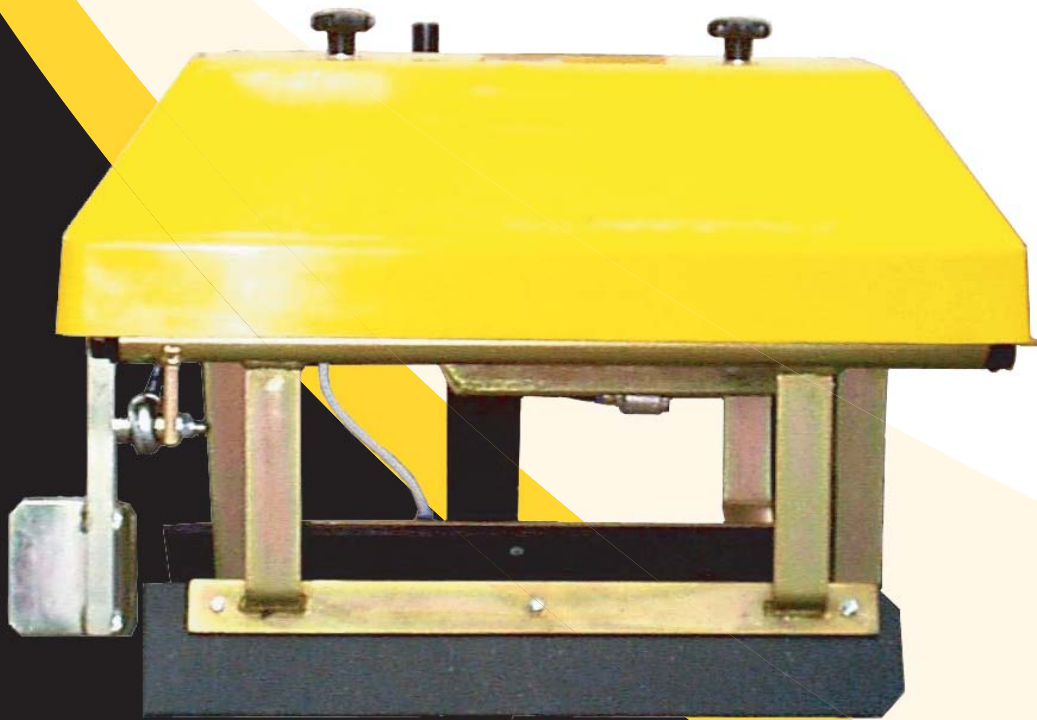

WALTHAMBURY®



M850

INFED AUTOMATOR

M850

INFEED AUTOMATOR

A simple, reliable, low cost stitcher automator for most makes of fixed head sack closer. Pneumatically operated for positive safe operation in dusty conditions the automator is particularly effective with normally difficult deep gusseted sacks. It can present at up to 12 bags/min with no operator supervision. Capable of handling from 12.5kg to 25kg paper sacks the automator has been designed with the minimum number of moving parts and adjustments needed for effective operation.

- Handles all types of multiwall paper, composite film and woven sacks of sufficient rigidity including deep gusseted between 12.5 & 25kg.
- Height adjustable pillar.
- Integral base unit for fixed head stitcher guarantees correct alignment (standard bases include Newlong NP7, Reed Medway HP1, Union Special and Fischbein).
- Photocell triggering and electro-pneumatic control.
- PLC control.

Optional Extras

- High-throughput version (18-21 bags per min at 12.5kg).
- Modification to suit small bags (To 6kg)

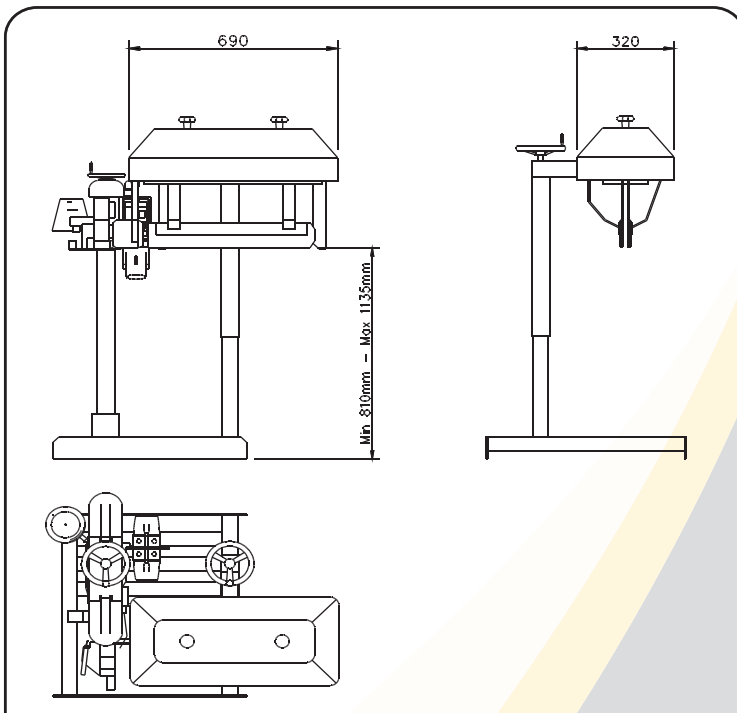

TECHNICAL SPECIFICATIONS

Throughput

10-12 bags per minute as standard.

Air Requirements

A cool dry air supply, 5.5bar (5cfm/142 ltr/min @ 80psi)

Conveyor Speed and Length

Speed: 30-45 ft/min range.

Length: 10ft (3 metres) length required.

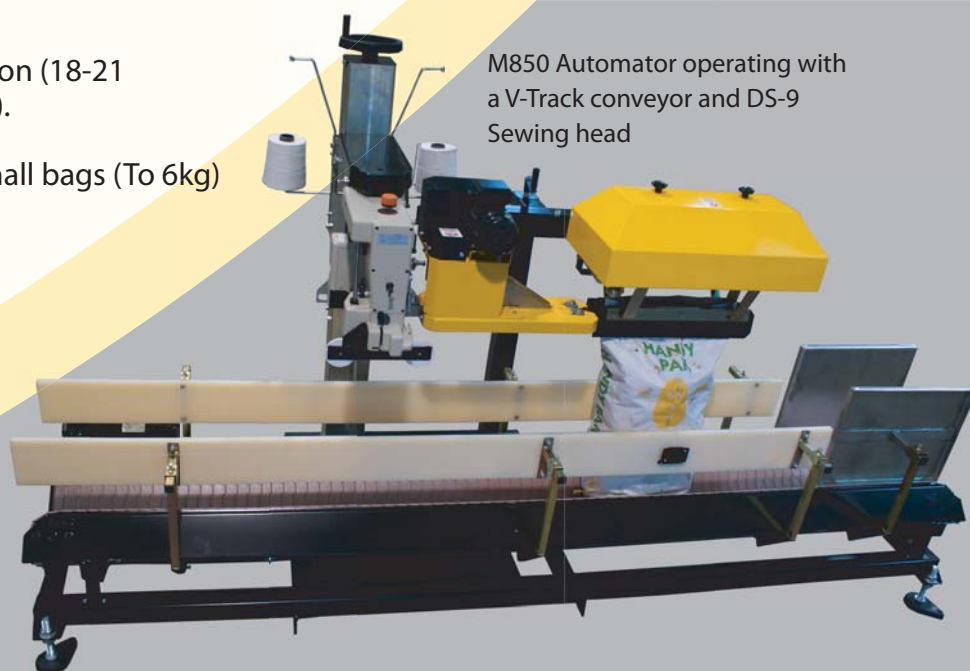

M850 Automator operating with a V-Track conveyor and DS-9 Sewing head

After Sales Service

Fast on site service by factory trained engineers coupled with extensive stocks of competitively priced spare parts guarantees maximum productivity and protects the customer's investment.

Walthambury® is a registered trademark of W. J. Morray Engineering.



Morray Engineering
New Walthambury House,
Anglia Way, Braintree,
Essex, CM7 3RG, UK.
Tel: +44 (0)1376 322722
Fax: +44 (0)1376 323277
E-Mail: sales@morray.com
www.morray.com